



Scan here for access to solution website page for other documents

Stravimech Bearing-S2 Datasheet



Stravimech Bearing-S2 is a spring mount featuring two metal springs isolators arranged in parallel. This configuration enhances load capacity and provides improved lateral stability. The system includes two mounting plates and can be paired with a levelling system. The dual-spring design delivers effective noise and vibration isolation for mechanical equipment, while allowing secure mechanical anchoring. It is particularly suitable for low-speed machinery and is designed to support medium load to heavy equipment where increased stability and load handling are essential.

FEATURES

- Designed to support all types of machinery operating at low frequencies (below 1200 rpm), ensuring effective vibration control
- 9 different models available, to accommodate design loads up to 8660 N (total loads up to 10000 N), suitable for a wide range of heavier machinery
- Springs are colour-coded for quick and accurate identification on-site
- Can be equipped with a levelling mechanism for precise height adjustment and alignment
- Bottom plate feature an elastomeric layer that improves anti-slip properties and adapts to surface irregularities
- Springs achieve natural frequencies of 3 Hz at design load, ensuring optimal vibration isolation
- Spring deflection goes up to 35 mm for consistent performance
- Springs are protected with a polyester-based coating, offering excellent resistance to environmental conditions
- Top and bottom cylindrical metal bushings include a visco-elastic putty layer that prevents metal-to-metal contact and promotes sound-stop

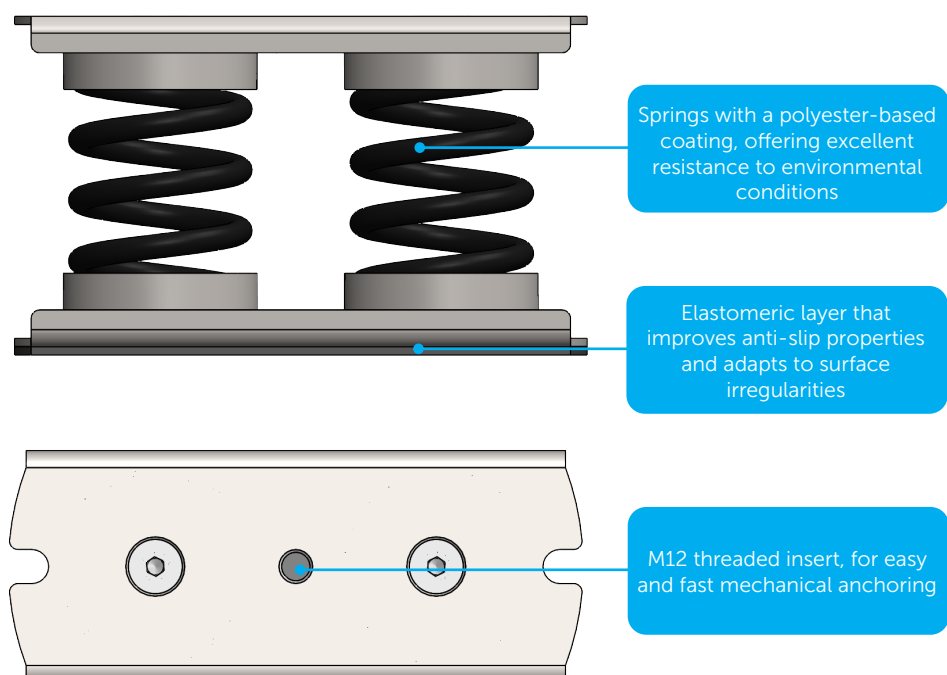



















PACKAGING

Model	Reference	Quantity per Box	Weight per Box [kg]	Dimension of Box [mm]
Stravimech Bearing-S2-2360	002154	1	2.09	200 x 200 x 140
Stravimech Bearing-S2-3150	002155	1	2.16	200 x 200 x 140
Stravimech Bearing-S2-3940	002156	1	2.28	200 x 200 x 140
Stravimech Bearing-S2-4725	002157	1	2.32	200 x 200 x 140
Stravimech Bearing-S2-5510	002158	1	2.35	200 x 200 x 140
Stravimech Bearing-S2-6300	002159	1	2.38	200 x 200 x 140
Stravimech Bearing-S2-7090	002160	1	2.41	200 x 200 x 140
Stravimech Bearing-S2-7875	002161	1	2.52	200 x 200 x 140
Stravimech Bearing-S2-8660	002162	1	2.62	200 x 200 x 140



PHYSICAL & MECHANICAL PROPERTIES

Model	Height	Design Load	Natural Frequency at Design Load	Load Range	Resistance to Uplift	Lateral Stiffness	Maximum Allowed Lateral Load	Spring Colour
	mm	N	Hz	N	N	N/mm	N	
Stravimech Bearing-S2-2360	118	2360	3	1710-3000	780	58,02	2060	Green + Green  
Stravimech Bearing-S2-3150		3150		2130-4000	950	76,80	2747	Yellow + Yellow  
Stravimech Bearing-S2-3940		3940		2560-5000	1260	92,44	3434	Brown + Brown  
Stravimech Bearing-S2-4725		4725		3030-6000	1380	109,79	4120	Brown + Grey  
Stravimech Bearing-S2-5510		5510		3510-7000	1500	127,14	4807	Grey + Grey  
Stravimech Bearing-S2-6300		6300		3910-8000	1550	144,88	5494	Grey + Orange  
Stravimech Bearing-S2-7090		7090		4620-9000	1600	162,62	6180	Orange + Orange  
Stravimech Bearing-S2-7875		7875		4970-9500	1640	170,71	6867	Orange + Black  
Stravimech Bearing-S2-8660		8660		5310-10000	1680	178,80	7554	Black + Black  

Notes:

- The products are suited to a C3 (medium duration) environment (urban and industrial atmospheres, moderate sulphur dioxide pollution, coastal areas with low salt content).
- Resistance to uplift is tested at room temperature.

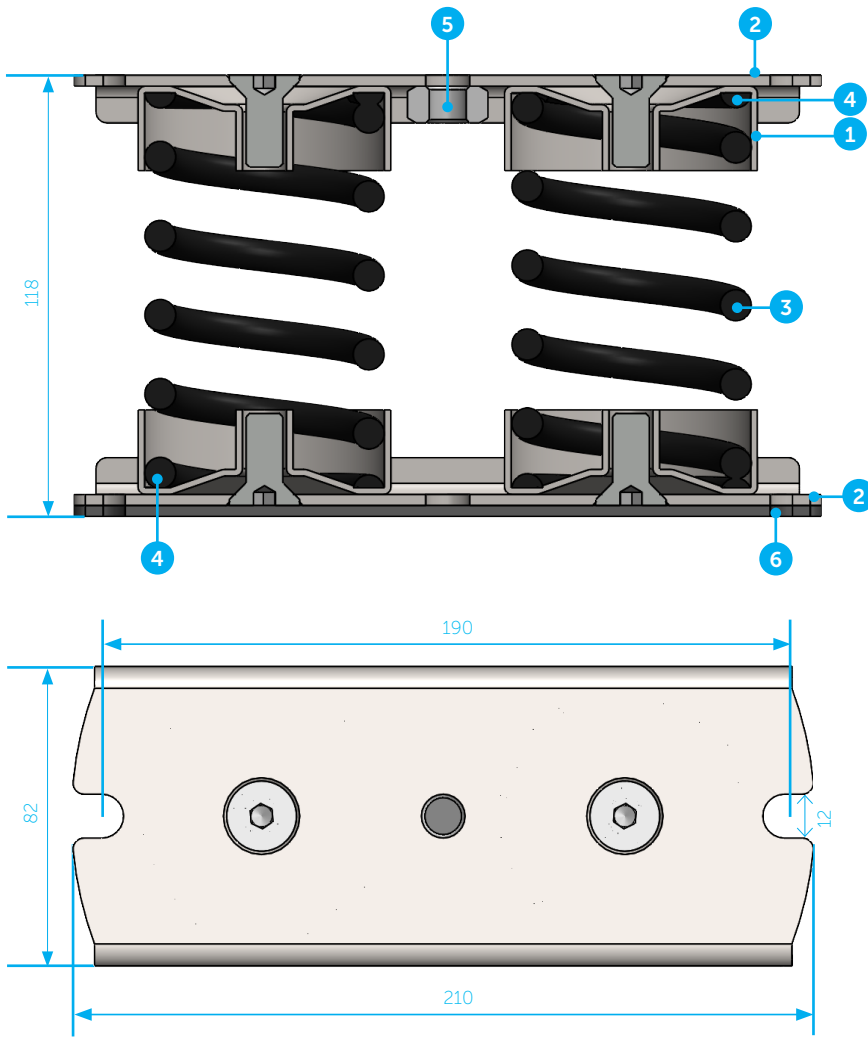

1. Steel bushings
2. Mounting plate
3. Polyester-based coated springs
4. Visco-elastic putty as soundstop
5. M12 threaded insert
6. Elastomeric layer

Note:
All dimensions in millimeters (mm).

To assess if the Stravimech system is appropriate CDM Stravitec's engineers will need the following information:

- Weight and load distribution of the machine to be supported on Stravimech Bearing supports
- Size and layout of support surfaces
- The dynamic loads generated by the machine
- Dimensional limits
- The required vibration isolation performance or natural frequency of the solution



PERFORMANCE GRAPHS

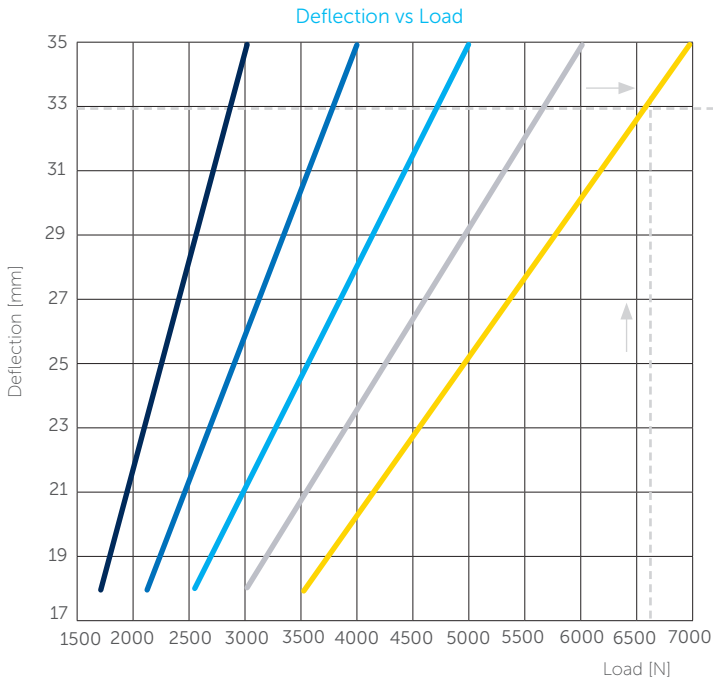

- Stravimech Bearing-S2-2360
- Stravimech Bearing-S2-3150
- Stravimech Bearing-S2-3940
- Stravimech Bearing-S2-4725
- Stravimech Bearing-S2-5510

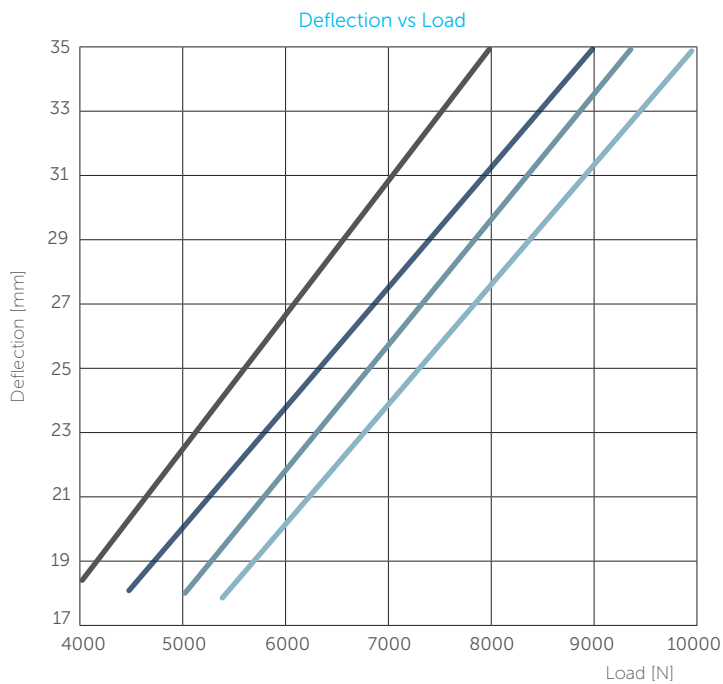
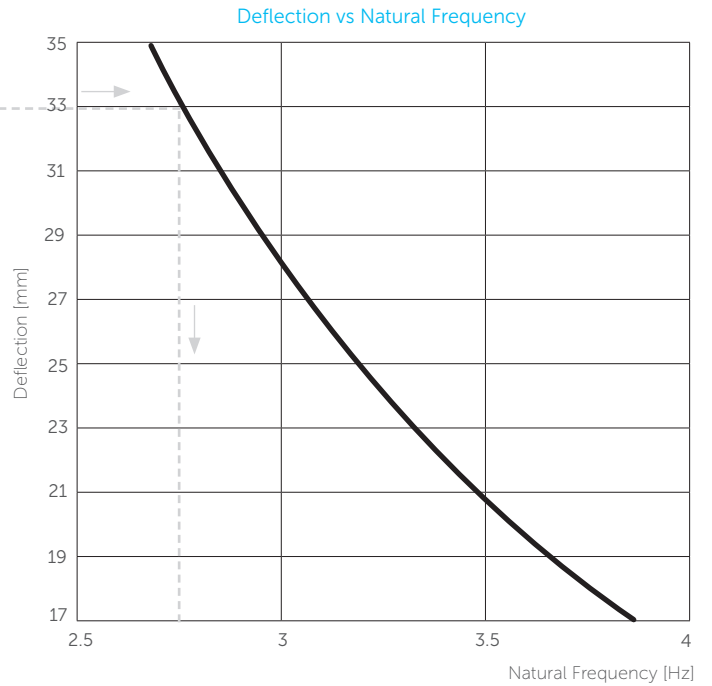

- Stravimech Bearing-S2-6300
- Stravimech Bearing-S2-7090
- Stravimech Bearing-S2-7875
- Stravimech Bearing-S2-8660

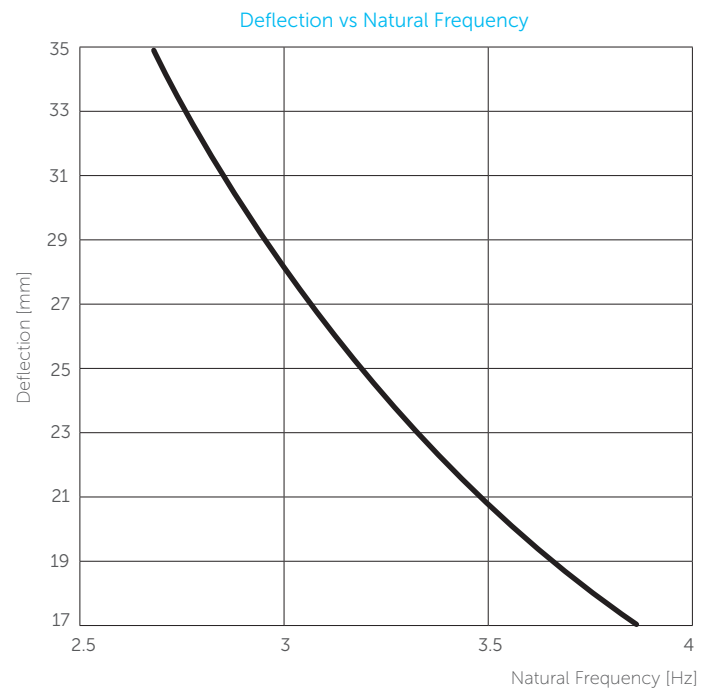

The natural frequency of a Stravimech isolator can be determined by its load. To start the calculation use the graph "deflection as function of load" this will provide the deflection at the specified load. Then moving horizontally to the right hand side plot "deflection as function of frequency" on which the corresponding natural frequency can be found. As an example, the natural frequency of a Stravimech Bearing-S2-5510 loaded with 6600 N is determined. The corresponding deflection is 33 mm. The natural frequency of a spring at 33 mm deflection is 2.75 Hz.



ACCESSORIES



Level Set

Levelling kit consisting of a threaded rod with nuts and washers for height adjustment.
Available in M12.



TYPICAL ASSEMBLIES

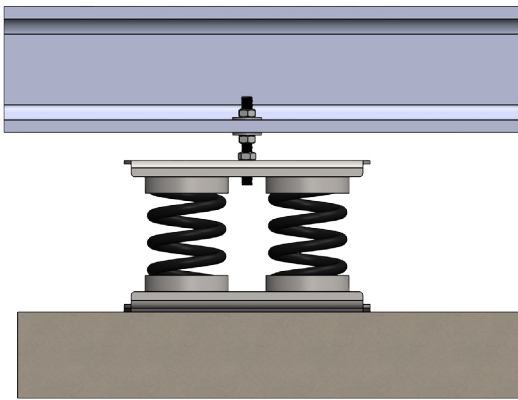

Stravimech Bearing-S2 with levelling*

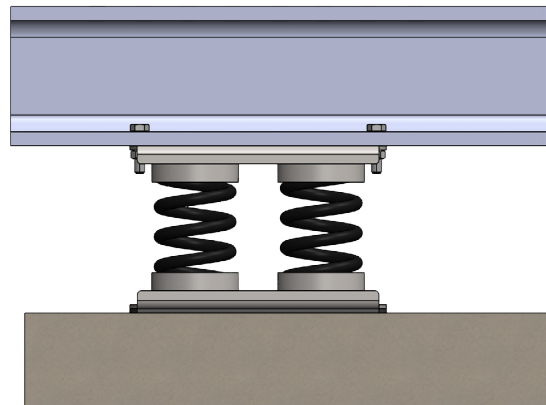

Stravimech Bearing-S2 directly assembled

*Levelling set available as accessory.

DISCLAIMER

This information is accurate to the best of our knowledge at the time of issue. Information, data and recommendations provided are based on industry accepted testing and prior product usage. It is intended as descriptive of the general capabilities and performance of our products and does not endorse applicability for any particular project. We reserve the right to change products, performance, and data without notice. This document replaces all information supplied prior to the publication hereof.